

(No Model.)

2 Sheets—Sheet 1.

R. A. CARTER. FLANGING MACHINE.

No. 350,412.

Patented Oct. 5, 1886.

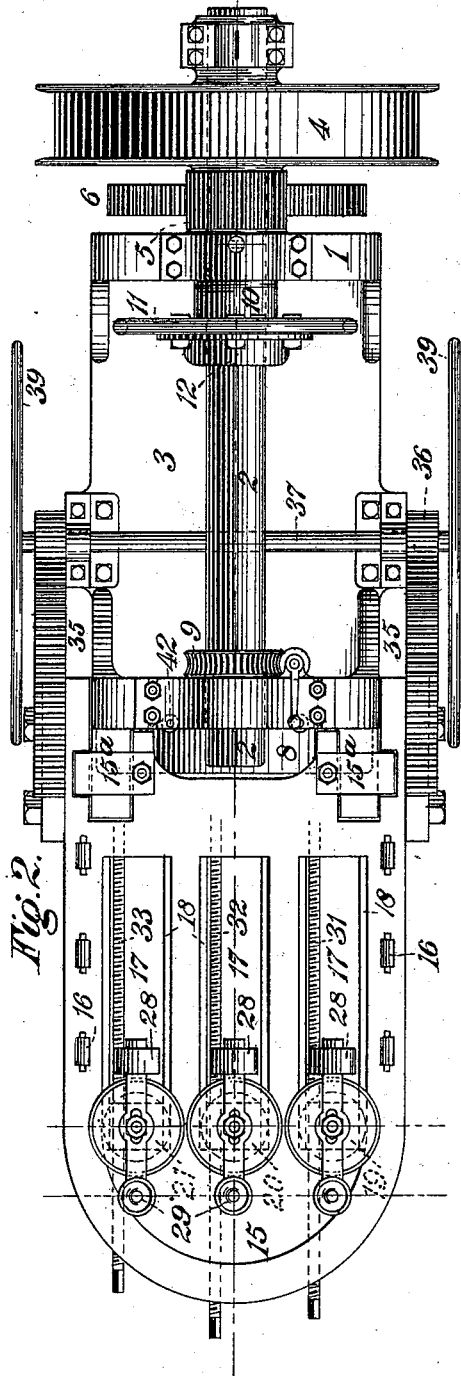
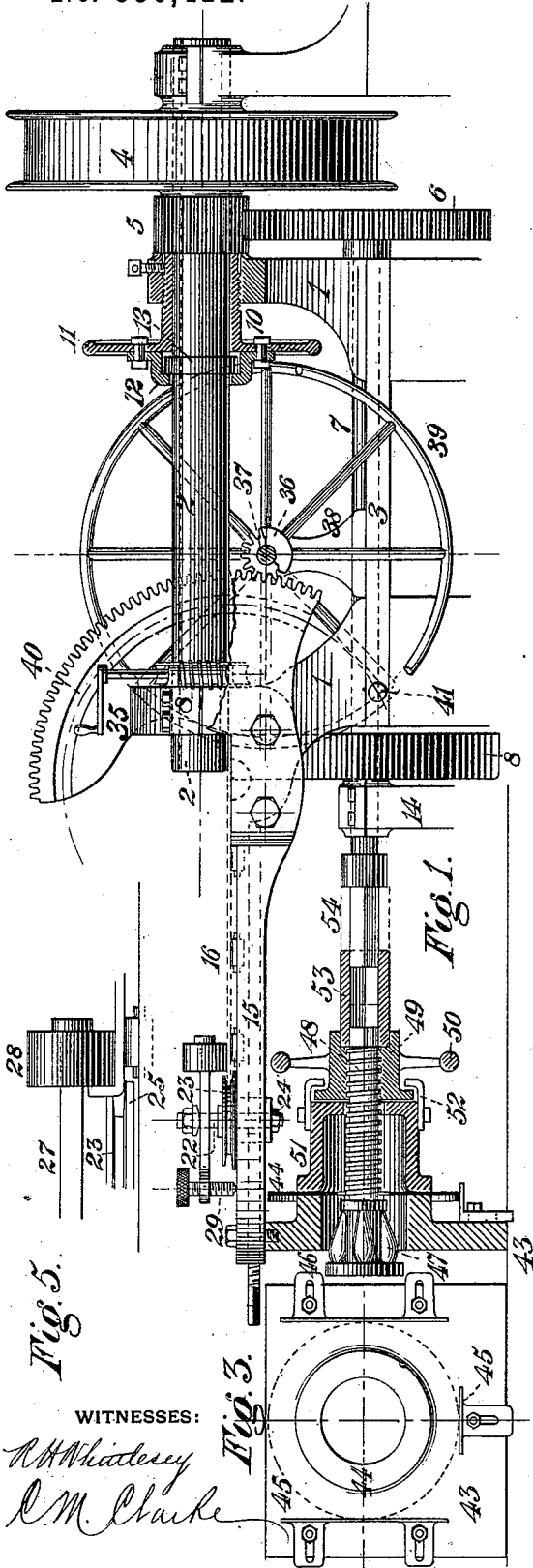

WITNESSES:

R. H. Whidery
E. M. Clarke

INVENTOR,

Robert A. Carter.
Demaris S. Wolcott
Att'y.

R. A. CARTER.
FLANGING MACHINE.

No. 350,412.

Patented Oct. 5, 1886.

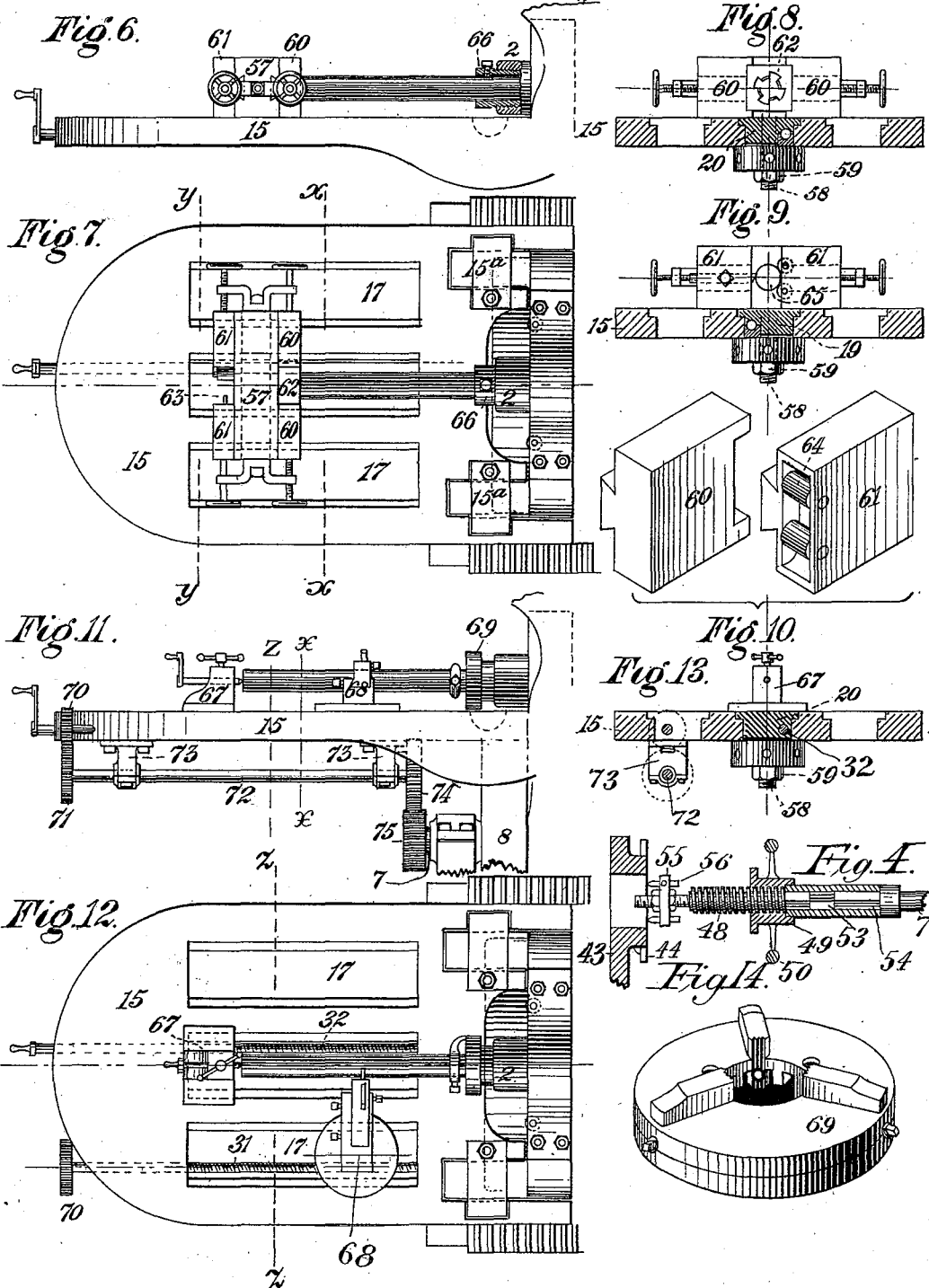

WITNESSES:

R. A. Whittelsey
C. M. Clarke

INVENTOR,

Robert A. Carter
by *Darius S. Wolcott*

Att'y.

UNITED STATES PATENT OFFICE.

ROBERT A. CARTER, OF PITTSBURG, PENNSYLVANIA, ASSIGNOR OF ONE-HALF TO JAMES M. BAILEY, OF SAME PLACE.

FLANGING-MACHINE.

SPECIFICATION forming part of Letters Patent No. 350,412, dated October 5, 1886.

Application filed June 2, 1886. Serial No. 203,934. (No model.)

To all whom it may concern:

Be it known that I, ROBERT A. CARTER, residing at Pittsburg, in the county of Allegheny and State of Pennsylvania, a citizen of the United States, have invented or discovered certain new and useful Improvements in Flanging-Machines, of which improvements the following is a specification.

In the accompanying drawings, which make part of this specification, Figure 1 is a view in side elevation of a flanging and nozzling machine embodying my invention. Fig. 2 is a top plan view of the same. Fig. 3 is a face view of the plate for supporting a plate during the cutting and nozzling operation. Fig. 4 is a detail view of the mechanism employed in cutting a plate prior to nozzling. Fig. 5 is a detail view of the rolls for guiding a plate during the flanging operation. Fig. 6 is a view in side elevation of the flanging-table and portion of the roll-housings, the table being provided with a sliding block provided with jaws for holding cutters and threading-dies. Fig. 7 is a top plan view of the same. Figs. 8 and 9 are sectional views on the lines *xx* and *yy*, respectively, of Fig. 7, the sliding block being shown in elevation. Fig. 10 shows two of the jaws of the sliding block. Fig. 11 is a view in side elevation of the flanging-table and front housing, the table being provided with a tail-stock and tool-rest and mechanism for operating the latter, the upper roll being provided with a suitable chuck. Fig. 12 is a top plan view of the same. Fig. 13 is a sectional view on the line *zz* of Fig. 12. Fig. 14 is a perspective view of a chuck for use with the upper roll.

The invention herein relates to certain improvements in machines employed in the manufacture of boilers and other like articles, and has for its object such a construction and combination of parts as will adapt the machine now employed for the flanging operation only to a large number of the operations necessary in the construction of boilers, which operations are now performed on separate and independent tools.

The constructions, combinations, and additions hereinafter described adapt the machine for use in flanging regularly and irregularly

shaped plates, nozzling, cutting, and threading pipes, bolts, or nuts, and also to such operations as require the use of lathes.

In general terms, the invention consists in the construction and combination of parts, substantially as hereinafter described and claimed.

The general construction and arrangement of the machine herein is similar to that shown and described in Letters Patent No. 328,274, dated October 13, 1885, the standards 1, for supporting the upper roll, 2, being formed or cast on the bed-plate 3, as shown and described in said patent, said bed-plate being mounted on a suitable foundation. The upper roll, 2, is made hollow throughout its entire length, as indicated by dotted lines in Fig. 1, for a purpose to be hereinafter stated, and on its rear end are mounted the driving-pulley 4 and the broad-faced pinion 5, adapted to inter-mesh with the gear-wheel 6 on the shaft 7 of the lower roll, 8. The forward end of the roll 2 is mounted in an eccentric adjusting-sleeve, as fully described and claimed in the patent above referred to, said sleeve being operated by a worm and gear, 9, as therein set forth. The rear bearing for the roll 2 is formed by a sleeve, 10, surrounding the roll and provided with exterior screw-threads for engagement with a threaded opening in the rear standard 1. (See Fig. 1.) On the front end of the sleeve 10 is formed or secured a hand operating wheel, 11, to which is bolted a ring, 12, provided with an inwardly-projecting flange, which engages a collar, 13, on the roll 2, thus locking the sleeve to the roll as regards longitudinal movement, any longitudinal adjustment of the roll being effected by rotating the sleeve in the standard 1. The shaft 7 of the lower roll, 8, is mounted at its rear end in suitable bearings in the rear standard, 1, and at its forward end in a post, 14, secured in any suitable manner to the machine. The swinging table 15 is pivoted or hinged to the front housings, in the manner described and shown in the patent above mentioned, and reference should be had thereto for such construction. One exception to the construction as set forth in said patent should be noticed, and that is in regard to the pintle-pin 15^a, the upper surface of which is shown par-

55

60

65

70

75

80

85

90

95

100

tially cut away in the patent, whereas it is now shown with its upper surface flush with the surface of the table, for the purpose of permitting of the flanging of rectangular plates, or such as have one or more straight edges. In the upper side of the table are mounted a series of friction-rolls, 16, having their axes parallel with the axis of the roll 2, and adapted to support the plate during the flanging operation.

In the table 15 are formed three or more longitudinal slots, 17, one of which is in line with the upper roll, 2, as shown. Along the edges of these slots are formed ways 18, for the reception of lateral wings projecting from sliding blocks 19, 20, and 21, located in said slots, the blocks being shown in dotted lines in Fig. 2. These blocks are held in position by nuts screwing onto a threaded boss on the lower ends of the blocks, said nuts bearing against the lower edges of the walls of the slots, as fully and specifically shown and described in the patent hereinbefore referred to.

Through the blocks 19, 20, and 21 are formed openings for the reception of the shafts 22, on which are mounted the guide-rolls 23, said shafts being held in position by the nuts 24, fitting on the threaded lower ends of said shafts. The rolls 23 are formed with peripheral grooves, the lower walls of said grooves being extended beyond the peripheries of the upper walls, as shown in Figs. 1, 2, and 5. The shafts 22 are extended above the rolls 23, and on them are secured the arms 27, and on the inner ends of these arms are mounted the pressure-rolls 28, and through the outer ends of said arms pass the adjusting-screws 29, bearing at their lower ends upon the table 15. In one side of the block 20 is formed a recess having one of its walls grooved and threaded, forming one half of a nut, the other half of said nut being formed by a removable block, 30, as shown in Figs. 8 and 9. The blocks 19 and 21 are similarly constructed. Through the nuts thus formed in the several blocks are passed the threaded rods 31, 32, and 33, (see Fig. 2,) said rods being supported and held at both ends as against longitudinal movement by straps or other suitable devices secured to the under side of the table. The ends of the rods project beyond the front end of the table, and are squared for the reception of a wrench or any suitable operating-tool.

To the arms 34 of the table 15 are bolted the toothed segments 35, with which the pinions 36 on the shaft 37 intermesh, said shaft being suitably journaled in standards 38, bolted to the bed-plate of the machine, and also being provided with hand-wheels 39, by which the shaft and pinions are rotated for raising and lowering the table.

In the inner faces of the segments 35 are formed circular grooves 40, which engage lugs 41, projecting from the bed-plate 3 or other part of the machine, when the table is turned to or is turned approximately to a vertical position, and prevent any lifting of the table

from its bearings during the flanging operation. The pulley 4 is driven by any suitable reversible mechanism.

The machine organized and arranged as above described is intended for flanging rectangular plates, or such as have one or more straight edges. In flanging rectangular plates the rolls 23 are adjusted to such relation with the edging-rolls 42, mounted in the face of the front housings, that the distance from the edging-rolls 42 to the bottom of the grooves in the rolls 23 is equal to the width of the plate to be flanged. The plate is then fed in edgewise between the rolls 2 and 8, and into the grooves in the rolls 23. The rolls 2 and 8 being started, the plate is drawn along between them, the table being gradually raised. As soon as the end of the plate is drawn into the rolls 2 and 8, or approximately so, they are reversed, thus moving the plate in the opposite direction. This back-and-forth movement of the plate is continued until the table is turned to a vertical position, or approximately so, and the flange on one edge formed. The plate is then withdrawn and reversed, the flanged edge being placed between the side of the rolls 28 and one wall of the groove in the rolls 23, the portion of the plate adjacent to the flange resting and being held upon wall or flange 25 of the rolls 23, as clearly shown in Fig. 5, by the rolls 28, the adjusting-screws 29 being operated to cause the rolls 28 to bear firmly upon the plate inside of the flange.

To adjust the rolls 28 to the varying thicknesses of plates to be operated the arms 27 are slotted, thereby permitting the rolls 28 to be moved to or from the rolls 23, as required. After the partially-flanged plate has been secured between the rolls 23 and 28, as above stated, the blocks 19, 20, and 21 are moved by the screws 31, 32, and 33 toward the flanging-rolls until the edge to be flanged rests against the edging-rolls 42. The flanging is then effected in the manner above stated. In case the machine is to be used for flanging circular plates, the rolls 23 and their connections are removed, and the circular plate can be secured to the block 20 in the manner described in the patent hereinbefore mentioned.

The next step in the operation is the formation of flue or man holes. This operation is effected by clamping the plate against the bed-plate 43, which is secured in any suitable manner in front of the machine, preferably immediately under the front end of the table 15, so as to serve as a support for the table when in a horizontal position, as shown. The bed-plate 43 is provided with an opening surrounded by an annular boss, 44, projecting inwardly, and with adjustable guides 45, arranged on each side and below the boss, as shown, for centering and supporting the plate to be operated on. The guides having been properly adjusted, the plate is placed in position and a hole cut therein by the device shown in Fig. 4, which will be hereinafter described. The cutting device being removed, the flue-forming

tool is substituted therefor. The flue-forming tool consists of a head, 46, provided with a series of friction-rollers, 47, arranged around its periphery. This head is secured to a threaded shaft, 48, on which is arranged a nut, 49, provided with handles 50. To this nut is attached the annular clamp 51, by means of clips 52, bolted to the clamp and engaging a flange formed on the nut. In forming the flue-hole the shaft 48 is passed through the hole in the plate from the front, as shown in Fig. 1. Then the nut and clamp are placed over the shaft and the former turned up until the head 46 is drawn partially into the hole in the plate, and the clamp presses the plate firmly against the boss 44. Then the squared end of the threaded shaft 48 is connected by a sliding sleeve, 53, to a squared section of shafting, 54, connected by a suitable coupling to the front end of the shaft 7 of the lower roll, 8, of the flanging-machine. By starting the machine the shaft 48 and head 46 are rotated, and, an operator holding the nut stationary, the head is drawn through the plate, forming a flanged flue-hole. As the shaft and head move along, the sleeve slides along the shaft-section 54.

In cutting holes in the plate a cutter-bar, 55, provided with radially-adjustable cutters 56, (see Fig. 4,) is substituted for the flanging-head 46. In using the cutter the plate is placed against the boss 44 of the bed-plate 43. The small end of the shaft 48 is then inserted through a small centering-hole in the plate, as shown. The shaft 48 is then rotated by the shaft 7, with which it is connected by the sleeve 53, said sleeve fitting over the squared section 54 and the similarly-shaped end of the shaft 48, and bearing at its ends against a shoulder on the shaft 7 and against the nut 49. As the shaft 48 is rotated, the nut 49 is held stationary, thereby causing a forward feed of said shaft 48, the nut being held against any rearward movement by the sleeve 53. The squared end of the shaft 48 should be sufficiently long to permit of the necessary longitudinal movement of said shaft without disengagement of the sleeve and squared end. As the motion of feed of the cutters is toward the bed-plate 43, the clamp 51 is omitted, the plate being held in position by the cutters.

To adapt the machine for cutting and threading pipes, a block, 57, (see Figs. 6 to 9,) provided with a threaded spindle, 58, is placed on the block 20, in the middle slot of the table, the block 57 being held in place by a nut, 59, screwing on the projecting end of the spindle 58. In each side of the block 57 are formed dovetailed grooves for the reception of correspondingly-shaped projections on slides 60 and 61. Two of these slides are arranged on each side of the block 57, the slides 60 on one side having their adjacent ends suitably shaped to clamp a threading-die, 62. (See Figs. 8 and 10.) One of the slides 61 on the opposite side of the block has a suitable cutting-blade, 63, secured therein, friction-rolls 64 being mounted in the end of the other slide. (See Figs. 7,

9, and 10.) An opening, 65, is formed through the block 57 for the passage of the pipe being cut or threaded.

In cutting or threading pipes a suitable chuck or clamp, 66, is secured in the end of the hollow upper roll, 2. Any form of chuck may be used; but I prefer to use one similar to that shown in Fig. 14, commonly known as a "universal" chuck, which can be attached to the roll 2 in any suitable manner.

If desired, a lathe tail-stock, 67, may be substituted for the block 57, said tail-stock being secured to the sliding block 20 in the same manner as the block 57, as shown in Fig. 13, and a tool rest or support, 68, can be attached to the block 19. (See Figs. 11 and 12.) If, now, a suitable chuck, 69—*e. g.*, the one shown in Figs. 11 and 12, or the one shown in Fig. 14—be attached to the roll 2, a complete turning-lathe adapted for all ordinary uses is formed.

In order to make the feed of the lathe automatic and also adapted for use in cutting screw-threads, a pinion, 70, is placed on the screw-rod 31, engaging the block 19, on which the tool-rest is mounted, and the pinion is arranged to engage a pinion, 71, on the counter-shaft 72, supported in hangers 73, bolted to the under side of the table 15. (See Fig. 11.) On the inner end of this counter-shaft is fastened another pinion, 74, engaging a gear-wheel secured to the shaft 7 of the under flanging-roll. By interposing idlers between the pinions 70 and 71, as is the usual practice in screw cutting lathes, any desired amount or direction of feed of the tool-rest can be produced.

While the table 15 is in use for the purposes hereinbefore mentioned other than flanging, I prefer to bolt it to the bed-plate 43, as shown in Fig. 1; or it may be held down by properly locking the hand-wheel 39.

I claim herein as my invention—

1. In a flanging-machine, a swinging table, slotted as described, in combination with one or more movable blocks located in said slots and one or more guide-rolls mounted on said blocks, substantially as set forth.

2. In a flanging-machine, a swinging table, slotted as described, in combination with one or more movable blocks located in said slots, one or more guide-rolls mounted on said blocks, and pressure-rolls also attached to said blocks, substantially as set forth.

3. In a flanging-machine, a swinging table, in combination with toothed segments secured to the table and provided with circular grooves, and lugs secured to or formed on a stationary part of the machine, substantially as set forth.

4. In a flanging-machine, the combination of the vertical bed-plate 43, a flanging-head secured to a threaded shaft, a nut carrying an annular clamp mounted on said shaft, the shaft 7 of the lower roll, 8, and a sliding coupling connecting the shaft 7 and the threaded shaft, substantially as set forth.

5. In a flanging-machine, a table slotted as

described, in combination with a block located in said slot, a clamping and cutting device secured to said block, and the hollow roll 2, provided with a suitable chuck, substantially as set forth.

5
6. In a flanging-machine, a table slotted as described, in combination with the blocks 19 and 20, located in said slots, a tail-stock and a tool-rest mounted on said blocks, and the roll 2, provided with a suitable chuck, substantially as set forth.

10
15
7. In a flanging-machine, the combination of a table slotted as described, blocks 19 and 20, located in said slots, a tail-stock and a tool-rest mounted on said blocks, a threaded shaft engaging the block 19, gearing connecting the threaded shaft and the shaft 7, and the roll 2, provided with a suitable chuck, substantially as set forth.

8. In a flanging-machine, a swinging table having half-journals, as described, in combination with segments secured to the table and provided with circular grooves, and lugs secured to a stationary part of the machine, substantially as set forth.

25
9. In a flanging-machine, the combination of the bed-plate 43, having an opening there-through, and lateral and vertical centering-guides, substantially as set forth.

In testimony whereof I have hereunto set my hand.

ROBERT A. CARTER.

Witnesses:

DARWIN S. WOLCOTT,
R. H. WHITTLESEY.